



**EQUALIZER**  
INTERNATIONAL™

# SW15TE

HYDRAULIC FLANGE  
SPREADER  
MINI KIT



**SPREADING FORCE = 15.5 T (155 kN)**

It is recommended that tools are used in pairs giving  
 $2 \times 15.5 = 31 \text{ T (310 kN)}$

**TOOL WEIGHT = 7 kg (15.4 lbs)**

## KIT COMPONENTS

- 1 x SW15TE Wedgehead
- 1 x 10,000 psi (700 bar) Hydraulic Cylinder
- 1 x Safety Block
- 1 x Instruction Manual
- 1 x Cardboard Packaging
- Product Code: SW15TEMIN



## WEIGHTS AND DIMENSIONS

- Tool with Hydraulic Cylinder = 7 kg (15.4 lb)
- Safety Block = 0.5 kg (1.1 lb)
- GROSS WEIGHT = 7.5 kg (16.5 lb)**

Packaging Dimensions: 190 x 180 x 320 mm (7.48" x 7.09" x 12.60")

### TOOL DIMENSIONS - CLOSED

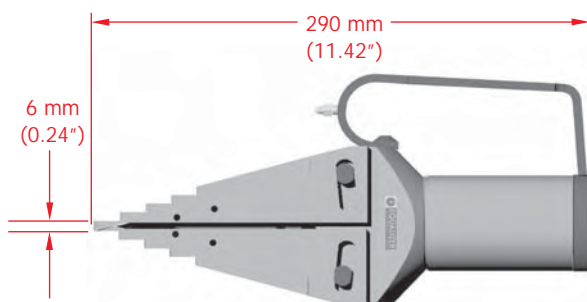

### TOOL DIMENSIONS - OPEN

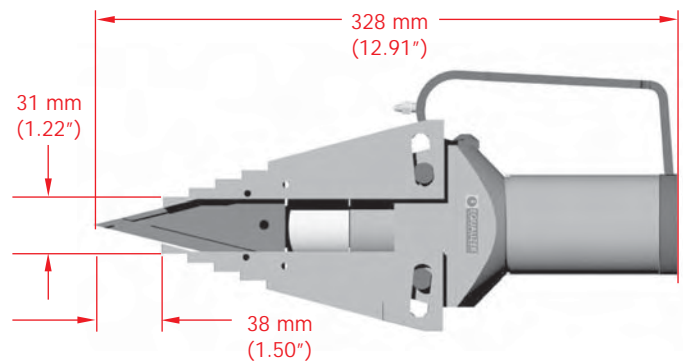



### TOOL DIMENSIONS - CLOSED

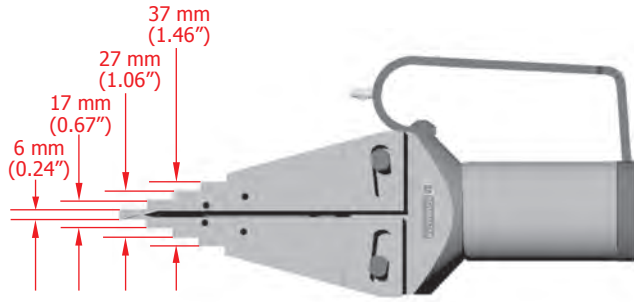

### TOOL DIMENSIONS - OPEN

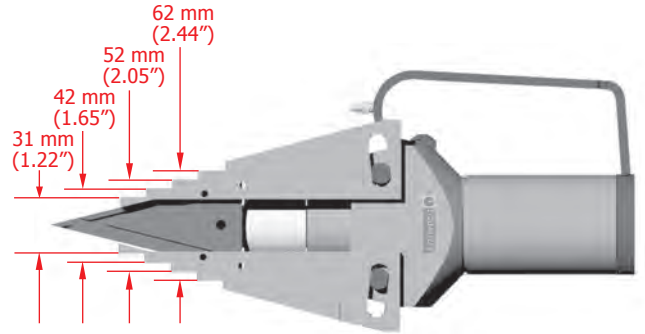

### SAFETY BLOCK DIMENSIONS

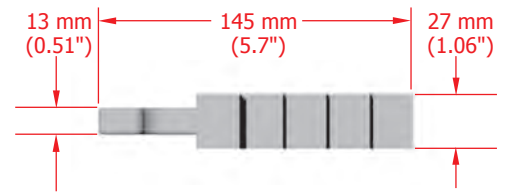
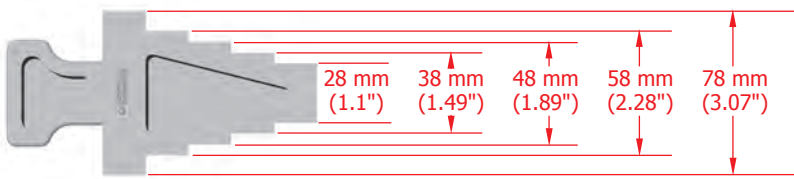

## RANGE OF APPLICATION

All flanges with a minimum access gap of 6 mm (0.24")

## PARTS LIST AND EXPLODED DRAWING

ITEM	PART No.	DESCRIPTION	QUANTITY
01	300701-01	HANDLE	01 each
02	401801-01	RETAINING SCREW FOR HANDLE	01 each
03	300203-02	JAWS	01 set of 2
04	301201-08	ROLL PINS	01 set of 8
05	300501-04	SLIDE PINS	01 set of 4
06	300301-01	CONNECTOR / PUSH ROD	01 each
07	300101-01	WEDGE	01 each
08	301301-01	GRUB SCREW	01 each
09	300401-04	GRUB SCREW	01 set of 4
10	301102-01	BODY	01 each
11	301002-01	HYDRAULIC CYLINDER	01 each
12	310601-01	GREASE NIPPLE	01 each
13	300801-02	BASE SCREWS FOR HANDLE	01 set of 2
14	301403-01	CYLINDER REPAIR KIT (Not Illustrated)	01 kit

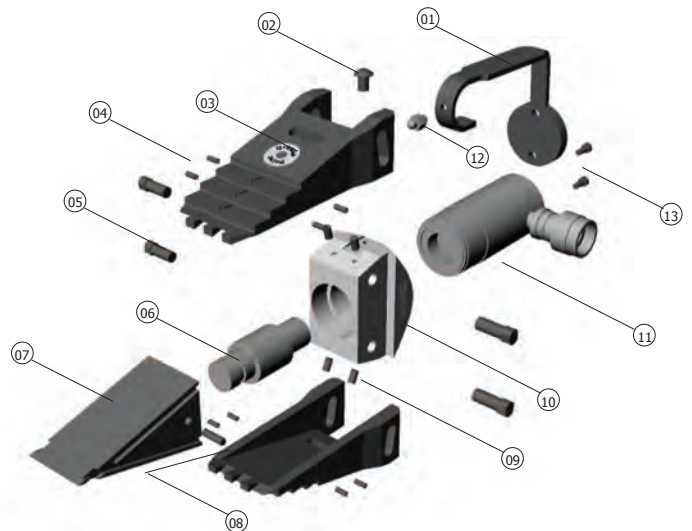

## STEPPED BLOCK KIT (AVAILABLE AS AN OPTION)

### KIT COMPONENTS

- 2 x Stepped Blocks
- 2 x M6 x 10 mm Countersunk Screws
- 1 x 4 mm Hex Key
- Kit Part No: 303301-01



## WEIGHTS AND DIMENSIONS

Stepped Block = 0.52 kg (1.14 lb)  
 GROSS WEIGHT = 1.5 kg (3.5 lb)

